



# HUCKLOK™ blind rivets



HUCKLOK™ blind rivets are especially high-strength blind rivets with a very wide gripping range that remain snug even under dynamic load. The mandrel always breaks flush, even when materials of varying strengths and thicknesses are present within the grip range. The blind-side footprint is minimal.

## Benefits at a glance

- High shear and tensile strength
- The securely fitting mandrel makes for vibration-resistant applications
- Very large grip range
- Mandrel always breaks off flush at the snap head
- Universal use
- Quick and secure installation
- Permanent secure fixing
- Heatless installation means component will not warp
- Eliminates extensive refinishing

## Applications

- General industry
- Steel construction and mechanical engineering
- Automotive industry
- Construction industry
- Bodywork and vehicle manufacture

# HUCKLOK™ blind rivets



## Truss head

### Material

#### Sleeve

Steel, galvanised,  
chromated

#### Mandrel

Steel, galvanised,  
chromated

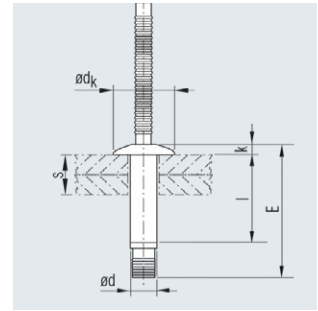

Nominal $\varnothing$ d [mm]	Bore $\varnothing$ [mm]	Grip range s [mm]	Blind sleeve l +1.0 -0.2 [mm]	Blind rivet head		Installation length E [mm]	Nominal strength at break*		Article No.
				$\varnothing$ dk $\pm 0.5$ [mm]	Height k $\pm 0.2$ [mm]		Shear N	Tensile N	
6.4	6.6 - 6.9	2.0 - 9.5	14.2	13.0	3.0	28.3	15560	8450	415 290 000
		4.8 - 11.0	15.7	13.0	3.0	29.9	15560	8450	415 291 000
		9.5 - 15.9	20.6	13.0	3.0	34.7	15560	8450	415 292 000
		15.9 - 22.2	26.9	13.0	3.0	41.1	15560	8450	415 294 000

\* Strengths at break relate to rivet failure.

Other designs available on request.