



TIFAS® Maxgrip blind rivets



The key feature of the TIFAS® Maxgrip is the design of the blind side footprint. As the rivet is being installed, the sleeve material moves radially outwards to form a disk-like blind side footprint. At the same time, the mandrel head does not plunge into the sleeve but deforms on swaging, much like a pair of bellows. Compared to standard blind rivets, the diameter of the blind side footprint generated by TIFAS® Maxgrip rivets is not only larger but their more favourable shape makes for a stronger fastening. The blind side footprint of the TIFAS® Maxgrip is larger, which enables the disk-shaped head to rest on the rivet. The level of resistance to the installed rivet becoming unriveted is therefore significantly higher.



Large grip range

When using conventional blind rivets, the thickness of the components that need to be joined may only vary to a small degree. For example, three different blind rivets of differing lengths need to be used for grip ranges of between 1.5 and 4.0 mm. The TIFAS® Maxgrip simplifies this situation as it requires just one rivet to cover a grip range of 1.5 - 4.0 mm.

Mandrel retention

In the automotive industry, it is imperative that blind rivets do not cause any rattling once they have been installed. Any possibility of the spent mandrel or any relative movement between the sleeve and the spent mandrel making a noise must be eliminated. By mechanically retaining the mandrel, the TIFAS® Maxgrip ensures every single time that the spent mandrel in the installed blind rivet sits securely even when subjected to heavy vibrations.

Watertight

The principle used with the TIFAS® Maxgrip of clamping the sleeve material against the mandrel to make sure the mandrel is retained also serves to seal the rivet sleeve bore. This means that the TIFAS® Maxgrip is also watertight.

Rolled mandrel

The body of the mandrel is rolled to extend the tool life of the jaws.

Lead-in chamfer

A lead-in chamfer on the rivet head facilitates insertion of the rivet into the bore and reduces rivet installation times.

Benefits at a glance

- High resistance to unripping
- Large hole tolerances permissible
- High reproducibility
- Lower bearing pressure
- Visually appealingly shaped, large blind side footprint

Applications

- Automotive industry
- General industry
- Bodywork and vehicle manufacture



TIFAS® Maxgrip blind rivets

Truss head with grooved mandrel

Material

Sleeve	Mandrel
Aluminium AlMg 3.5	Steel, galvanised

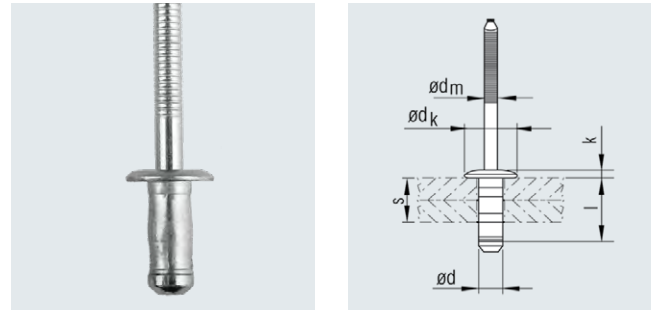

Nominal \varnothing d [mm]	Bore \varnothing [mm]	Grip range s [mm]	Blind sleeve l +1.0 -0.2 [mm]	Blind rivet head \varnothing dk \pm 0.3 [mm]	Height k max. [mm]	Mandrel \varnothing dm max. [mm]	Nominal strength at break*		Article No.
							Shear N	Tensile N	
4.8	4.9	1.5 - 4.0	11.0	9.5	1.5	3.0	1400	2000	413 295 000
		4.0 - 7.0	13.5	9.5	1.5	3.0	1400	2000	413 296 000
		7.0 - 10.0	17.0	9.5	1.5	3.0	1400	2000	413 297 000

* Strengths at break relate to rivet failure

The shear strength at break is impacted by where the spent mandrel is located on the area of break.

Other designs available on request.