



Tubtara® blind rivet nuts

Low profile head

Round shank, open end
 - No need to countersink holes

Material

 Aluminium

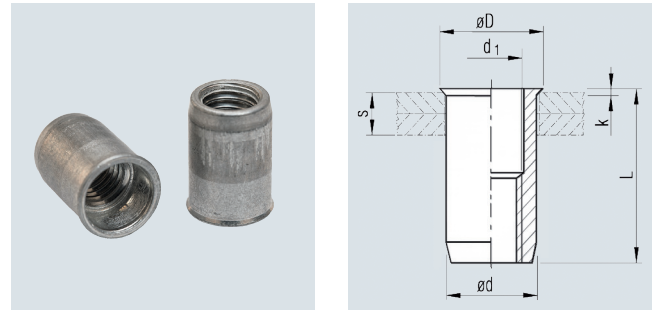

| Thread | Grip range | Hole ø | Shank ø | Head ø | Head height | Shank length | Description | Article No. |
|-----------|-------------|-------------|----------------------|---------------------|---------------------|----------------|-------------|-------------|
| d1 | s | +0.1 | d -0.02 -0.15 | D -0.15 +0.3 | k -0.05 +0.3 | L ±0.35 | | |
| 6H | [mm] | [mm] | [mm] | [mm] | [mm] | [mm] | | |
| M 4 | 0.5 - 3.0 | 6.0 | 6.0 | 6.5 | 0.5 | 10.75 | UK030 | 335 443 000 |
| M 5 | 0.5 - 3.0 | 7.0 | 7.0 | 7.5 | 0.5 | 12.0 | UK030 | 335 453 000 |
| M 6 | 0.5 - 3.0 | 9.0 | 9.0 | 9.5 | 0.5 | 14.5 | UK030 | 335 473 000 |
| M 8 | 0.5 - 3.0 | 11.0 | 11.0 | 11.5 | 0.5 | 16.0 | UK030 | 335 483 000 |



Tubtara® blind rivet nuts

Low profile head

Round shank, open end
- No need to countersink holes

Material

Steel, Zinktop 480h

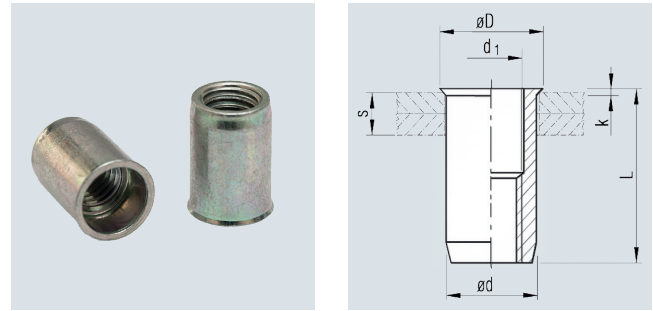

| Thread | Grip range | Hole ø | Shank ø | Head ø | Head height | Shank length | Description | Article No. |
|--------|------------|--------|-------------------|--------------|--------------|--------------|-------------|-------------|
| d1 | s | +0.1 | d -0.02 -0.15 | D -0.15 +0.3 | k -0.05 +0.3 | L ±0.35 | | |
| 6H | [mm] | [mm] | [mm] | [mm] | [mm] | [mm] | | |
| M 4 | 0.5 - 3.0 | 6.0 | 6.0 | 6.5 | 0.5 | 10.75 | UK030 | 335 263 950 |
| | 3.0 - 5.0 | 6.0 | 6.0 | 6.5 | 0.5 | 12.75 | UK050 | 335 264 950 |
| M 5 | 0.5 - 3.0 | 7.0 | 7.0 | 7.5 | 0.5 | 12.0 | UK030 | 335 283 950 |
| | 3.0 - 5.5 | 7.0 | 7.0 | 7.5 | 0.5 | 15.0 | UK055 | 335 284 950 |
| M 6 | 0.5 - 3.0 | 9.0 | 9.0 | 9.5 | 0.5 | 14.5 | UK030 | 335 293 950 |
| | 3.0 - 5.5 | 9.0 | 9.0 | 9.5 | 0.5 | 16.5 | UK055 | 335 294 950 |
| M 8 | 0.5 - 3.0 | 11.0 | 11.0 | 11.5 | 0.5 | 16.0 | UK030 | 335 303 950 |
| | 3.0 - 5.5 | 11.0 | 11.0 | 11.5 | 0.5 | 18.5 | UK055 | 335 304 950 |
| M 10 | 0.8 - 3.5 | 12.5 | 12.4 ³ | 12.9 | 0.5 | 19.5 | UK035 | 335 313 950 |

³ Shank ø tolerance: ±0.08



Tubtara® blind rivet nuts

Low profile head

Round shank, open end
- No need to countersink holes

Material

Stainless steel AISI 304 Cu 1.4567

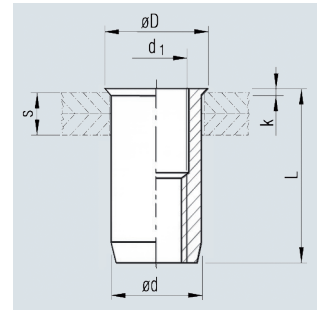

| Thread | Grip range | Hole \varnothing | Shank \varnothing | Head \varnothing | Head height | Shank length | Description | Article No. |
|-----------|-------------|--------------------|----------------------|---------------------|---------------------|-------------------------------|-------------|-------------|
| d1 | s | +0.1 | d -0.02 -0.15 | D -0.15 +0.3 | k -0.05 +0.3 | L \pm0.35 | | |
| 6H | [mm] | [mm] | [mm] | [mm] | [mm] | [mm] | | |
| M 4 | 0.5 - 2.0 | 6.0 | 6.0 | 6.5 | 0.5 | 11.0 | UK020 | 334 260 000 |
| M 5 | 0.5 - 3.0 | 7.0 | 7.0 | 7.5 | 0.5 | 12.0 | UK030 | 334 283 000 |
| | 3.0 - 5.0 | 7.0 | 7.0 | 7.5 | 0.5 | 15.0 | UK050 | 334 284 000 |
| M 6 | 0.5 - 3.0 | 9.0 | 9.0 | 9.5 | 0.5 | 14.5 | UK030 | 334 293 000 |
| | 3.0 - 5.0 | 9.0 | 9.0 | 9.5 | 0.5 | 16.5 | UK050 | 334 294 000 |
| M 8 | 0.5 - 3.0 | 11.0 | 11.0 | 11.5 | 0.5 | 16.0 | UK030 | 334 303 000 |
| | 3.0 - 5.5 | 11.0 | 11.0 | 11.5 | 0.5 | 18.5 | UK055 | 334 304 000 |
| M 10 | 0.8 - 3.5 | 13.0 | 13.0 | 13.5 | 0.5 | 21.0 ⁴ | SK035 | 334 314 000 |
| | 3.5 - 6.0 | 13.0 | 13.0 | 13.5 | 0.5 | 23.5 ⁴ | SK060 | 334 315 000 |
| M12 | 1.0 - 4.0 | 16.0 | 16.0 | 16.8 | 0.7 | 26.0 | UK040 | 334 317 000 |

⁴ Shank length (L) tolerance: \pm 0.5



Tubtara® blind rivet nuts

Low profile head

Round shank, open end
- No need to countersink holes

Material

Steel, AISI 316 Cu 1.4578

Exceptionally high corrosion resistance

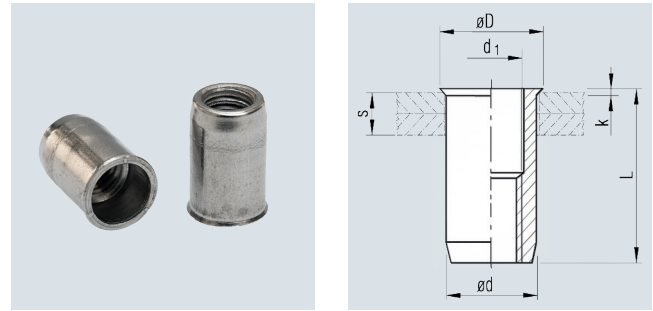

| Thread | Grip range | Hole ø | Shank ø | Head ø | Head height | Shank length | Description | Article No. |
|--------|------------|--------|---------------|--------------|--------------|-------------------|-------------|-------------|
| d1 | s | +0.1 | d -0.02/-0.15 | D -0.15 +0.3 | k -0.05 +0.3 | L ±0.35 | | |
| 6H | [mm] | [mm] | [mm] | [mm] | [mm] | [mm] | | |
| M 4 | 0.5 - 2.0 | 6.0 | 6.0 | 6.5 | 0.5 | 11.0 | UK020 | 334 246 000 |
| M 5 | 0.5 - 3.0 | 7.0 | 7.0 | 7.5 | 0.5 | 12.0 | UK030 | 334 286 000 |
| | 3.0 - 5.0 | 7.0 | 7.0 | 7.5 | 0.5 | 15.0 | UK050 | 334 287 000 |
| M 6 | 0.5 - 3.0 | 9.0 | 9.0 | 9.5 | 0.5 | 14.5 | UK030 | 334 295 000 |
| | 3.0 - 5.0 | 9.0 | 9.0 | 9.5 | 0.5 | 16.5 | UK050 | 334 296 000 |
| M 8 | 0.5 - 3.0 | 11.0 | 11.0 | 11.5 | 0.5 | 16.0 | UK030 | 334 306 000 |
| | 3.0 - 5.5 | 11.0 | 11.0 | 11.5 | 0.5 | 18.5 | UK055 | 334 307 000 |
| M 10 | 0.8 - 3.5 | 13.0 | 13.0 | 13.5 | 0.7 | 21.0 ⁴ | SK035 | 334 316 000 |
| | 3.5 - 6.0 | 13.0 | 13.0 | 13.5 | 0.7 | 23.5 ⁴ | SK060 | 334 318 000 |

⁴ Shank length (L) tolerance: ±0.5