

RL 75N

Hydropneumatic rivet installation tool for installing lockbolts and high-strength blind rivets

Benefits at a glance

- High performance
- New valve control for faster installation speeds
- Quick-release mandrel container
- Low-noise
- Easy to use; requires little maintenance
- Air supply fittable on left or right
- Fixing point for balancer
- Safety valve prevents operating pressure overload
- Reliable and tried-and-tested

Technical specifications

Stroke:	15.0 mm
Insertion force:	22 kN at 6 bar
Installation force/Weight ratio:	10 kN/kg
Air consumption:	2.8 l/rivet
Connection pressure:	5 - 7 bar
Air supply:	ø 6 mm (G1/4")
Weight:	2.2 kg

Scope of delivery

RL 75N rivet installation tool
 Oil refill set
 Angled air supply
 Mandrel collector
 Operating instructions
Article No. 385 060 300

Note

Pulling heads sold separately
 See table for product selection

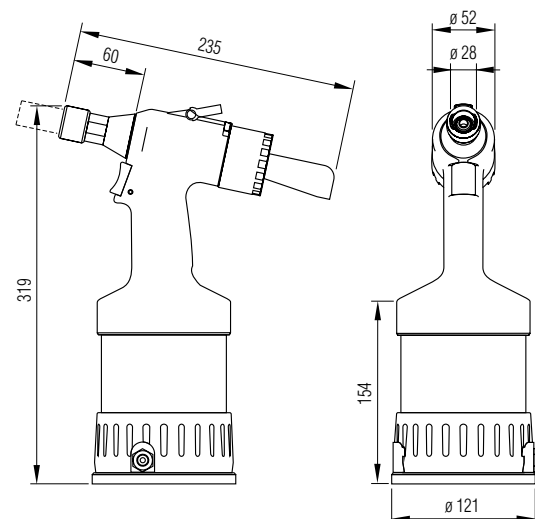



Working range - lockbolts

Fastener	Standard lockbolt ø [mm]				DeltaBolt® lockbolt ø [mm]				Multigrip lockbolt ø [mm]				Hucktainer® Plus ø [mm]
	4.8	6.4	8.0	9.6	4.8	6.4	8.0	9.6	4.8	6.4	7.8	9.6	9.5
Aluminium	•	•							•	•			
Steel	•	•			•	•			•	•			•
Stainless steel	•	•							•	•			

Working range - high-strength blind rivets

Fastener	TIBULB blind rivet ø [mm]			M-LOCK blind rivet ø [mm]			MAGNA-BULB blind rivet ø [mm]			BOM blind rivet ø [mm]			
	4.8	6.4	7.8	4.8	6.4	9.5	4.8	6.4	7.8	4.8	6.4	7.8	9.5
Aluminium	•	•		•	•								
Steel	•	•	•	•	•		•	•		•			
Stainless steel	•	•		•	•								

Pulling heads for RL 75N

Fastener	Nominal bolt ø [mm]	Pulling head type	Article No.
Standard lockbolts	4.8	99-3003	371 680 000
	6.4	99-3006	371 705 000
	8.0		
	9.6		
DeltaBolt® lockbolts	4.8	99-3003	371 680 000
	6.4	99-3006	371 705 000
	8.0		
	9.6		
Multigrip lockbolts	4.8	99-1456	372 985 000
	6.4	99-1477UK	371 980 000
	7.8		
	9.6		
Hucktainer® Plus TIBULB blind rivets	9.5	99-3465	371 730 000
	4.8	99-3303	371 805 000
	6.4	99-3305	371 815 000
	7.8	20-0353	385 150 000
M-LOCK blind rivets	4.8	99-3303	371 805 000
	6.4	99-3305	371 815 000
	9.5		
MAGNA-BULB blind rivets	4.8	99-3303	371 805 000
	6.4	99-3305	371 815 000
	7.8		
BOM blind rivets	4.8	99-994	372 780 000
	6.4		
	7.8		
	9.5		

Optional accessories

Description	Article No.
Reinforced mandrel container	385 717 870
Inductive ring sensor	431 784 000
Hydraulic oil 1 l	460 299 870

For technical specifications on pulling heads, see table on pages 24/25.



HUCK 2025LB

Hydropneumatic rivet installation tool for installing lockbolts and high-strength blind rivets

Benefits at a glance

- Ergonomic handle
- Chrome-plated piston rod
- In-line plunger
- Low-weight

Technical specifications

Stroke:	17.0 mm
Insertion force:	23.5 kN at 6 bar
Length:	213 mm (without pulling head)
Height:	319 mm
Weight:	2.6 kg

Scope of delivery

HUCK 2025LB rivet installation tool
Oil fill accessory kit
Operating instructions
Article No. 370 120 000

Note

Pulling heads sold separately
See table for product selection





Working range - lockbolts

Fastener	Standard lockbolt ø [mm]				DeltaBolt® lockbolt ø [mm]				Multigrip lockbolt ø [mm]				Hucktainer® Plus ø [mm]
	4.8	6.4	8.0	9.6	4.8	6.4	8.0	9.6	4.8	6.4	7.8	9.6	9.5
Aluminium	•	•							•	•			
Steel	•	•			•	•			•	•			•
Stainless steel	•	•							•	•			

Working range - high-strength blind rivets

Fastener	TIBULB blind rivet ø [mm]			M-LOCK blind rivet ø [mm]			MAGNA-BULB blind rivet ø [mm]			BOM blind rivet ø [mm]			
	4.8	6.4	7.8	4.8	6.4	9.5	4.8	6.4	7.8	4.8	6.4	7.8	9.5
Aluminium	•	•		•	•								
Steel	•	•		•	•		•	•					
Stainless steel	•	•		•	•								

Pulling heads for HUCK 2025LB

Fastener	Nominal bolt ø [mm]	Pulling head type	Article No.
Standard lockbolts	4.8	99-30031	371 680 000
	6.4	99-30061	371 705 000
	8.0		
	9.6		
DeltaBolt® lockbolts	4.8	99-30031	371 680 000
	6.4	99-30061	371 705 000
	8.0		
	9.6		
Multigrip lockbolts	4.8	99-14561	372 985 000
	6.4	99-1477UK	371 980 000
	7.8		
	9.6		
Hucktainer® Plus TIBULB blind rivets	9.5	99-3464L	on request
	4.8	99-33031	371 805 000
	6.4	99-33051	371 815 000
	7.8		
M-LOCK blind rivets	4.8	99-33031	371 805 000
	6.4	99-33051	371 815 000
	9.5		
MAGNA-BULB blind rivets	4.8	99-33031	371 805 000
	6.4	99-33051	371 815 000
	7.8		
BOM blind rivets	4.8		
	6.4		
	7.8		
	9.5		

For technical specifications on pulling heads, see table on pages 24/25.



HUCK 254

Hydropneumatic rivet installation tool for installing lockbolts and high-strength blind rivets

Benefits at a glance

- Ergonomic two-finger trigger
- One-piece reinforced piston
- Low-throttle safeguard for added protection from dirt entering the throttle valve
- High insertion force at less than 4.0 kg weight

Technical specifications

Stroke: 14.3 mm
 Insertion force: 38.3 kN at 6.2 bar
 Weight: 3.9 kg

Scope of delivery

HUCK 254 rivet installation tool
 Oil fill accessory kit
 Operating instructions
 Article No. 375 200 000

Note

Pulling heads sold separately
 See table for product selection

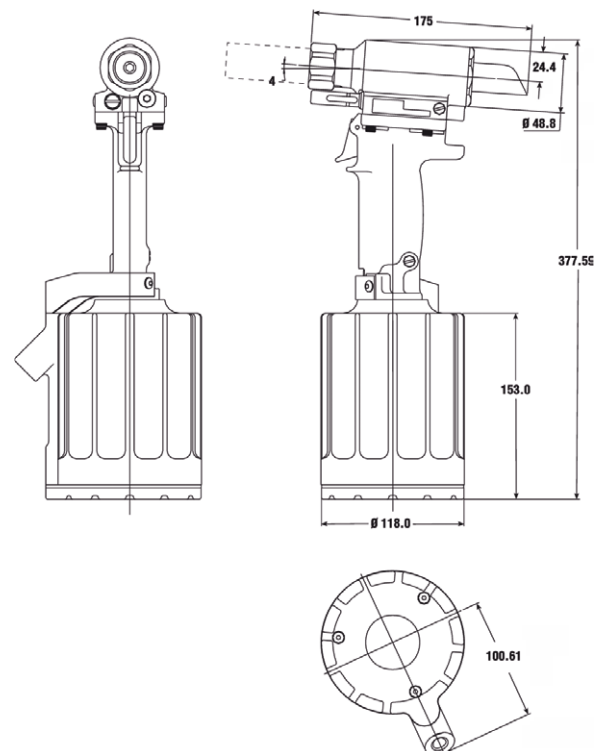



Working range - lockbolts

Fastener	Standard lockbolt ø [mm]				DeltaBolt® lockbolt ø [mm]				Multigrip lockbolt ø [mm]				Hucktainer® Plus ø [mm]
	4.8	6.4	8.0	9.6	4.8	6.4	8.0	9.6	4.8	6.4	7.8	9.6	9.5
Aluminium	•	•	•	•					•	•	•	•	
Steel	•	•	•	•	•	•	•	•	•	•	•	•	•
Stainless steel	•	•	•						•	•	•		

Working range - high-strength blind rivets

Fastener	TIBULB blind rivet ø [mm]			M-LOCK blind rivet ø [mm]			MAGNA-BULB blind rivet ø [mm]			BOM blind rivet ø [mm]			
	4.8	6.4	7.8	4.8	6.4	9.5	4.8	6.4	7.8	4.8	6.4	7.8	9.5
Aluminium			•			•							
Steel			•			•			•	•	•		
Stainless steel			•			•							

Pulling heads for HUCK 254

Fastener	Nominal bolt ø [mm]	Pulling head type	Article No.
Standard lockbolts	4.8	99-2558	on request
	6.4	99-2564	375 845 000
	8.0	99-99-245	375 885 000
	9.6	99-100-245	375 945 000
DeltaBolt® lockbolts	4.8	99-2558	on request
	6.4	99-2564	375 845 000
	8.0	99-99-245	375 885 000
	9.6	99-100-245	375 945 000
Multigrip lockbolts	4.8	99-1456 ²	372 985 000
	6.4	99-1477UK ²	371 980 000
	7.8	99-1439	371 965 000
	9.6	99-1440	371 970 000
Hucktainer® Plus TIBULB blind rivets	9.5	99-3438	on request
	4.8		
	6.4		
M-LOCK blind rivets	7.8	99-3307	385 159 000
	4.8		
	6.4		
MAGNA-BULB blind rivets	9.5	99-3318	371 904 000
	4.8		
	6.4		
BOM blind rivets	7.8	99-3307	385 159 000
	4.8		
	6.4		
BOM blind rivets	4.8	99-1053	on request
	6.4	99-830-1	372 550 000
	7.8		
	9.5		

² Only to be fitted using a connector Article No. 375 870 000

For technical specifications on pulling heads, see table on pages 24/25.



HUCK 256

Hydropneumatic rivet installation tool for installing lockbolts and high-strength blind rivets

Benefits at a glance

- Ergonomic handle
- Chrome-plated piston rod
- In-line plunger
- High insertion force
- For fast installation times in production

Technical specifications

Stroke: 22.2 mm
Insertion force: 44.4 kN at 6.2 bar
Weight: 5.0 kg

Scope of delivery

HUCK 256 rivet installation tool
Oil fill accessory kit
Operating instructions
Article No. 375 490 000

Note

Pulling heads sold separately
See table for product selection

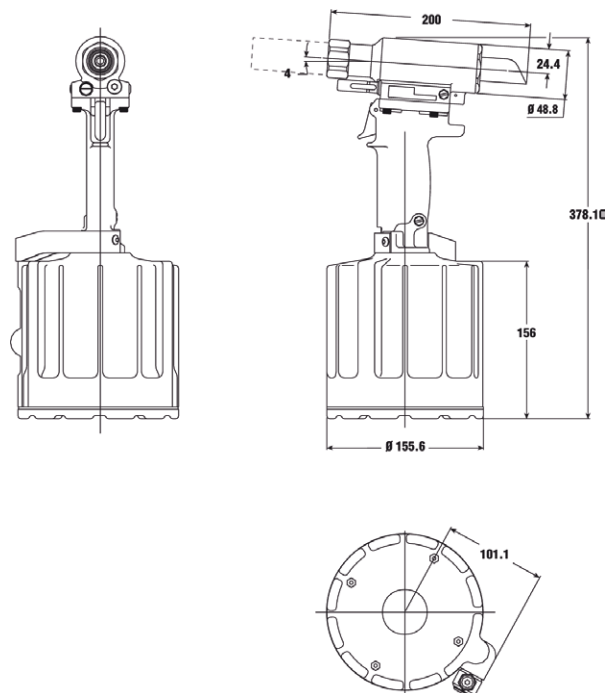



Working range - lockbolts

Fastener	Standard lockbolt ø [mm]				DeltaBolt® lockbolt ø [mm]				Multigrip lockbolt ø [mm]				Hucktainer® Plus ø [mm]
	4.8	6.4	8.0	9.6	4.8	6.4	8.0	9.6	4.8	6.4	7.8	9.6	9.5
Aluminium	•	•	•	•					•	•	•	•	
Steel	•	•	•	•	•	•	•	•	•	•	•	•	•
Stainless steel	•	•	•	•					•	•	•	•	

Working range - high-strength blind rivets

Fastener	TIBULB blind rivet ø [mm]			M-LOCK blind rivet ø [mm]			MAGNA-BULB blind rivet ø [mm]			BOM blind rivet ø [mm]			
	4.8	6.4	7.8	4.8	6.4	9.5	4.8	6.4	7.8	4.8	6.4	7.8	9.5
Aluminium													
Steel						•			•	•	•		
Stainless steel													

Pulling heads for HUCK 256

Fastener	Nominal bolt ø [mm]	Pulling head type	Article No.
Standard lockbolts	4.8	99-2558	on request
	6.4	99-2564	375 845 000
	8.0	99-99-245	375 885 000
	9.6	99-100-245	375 945 000
DeltaBolt® lockbolts	4.8	99-2558	on request
	6.4	99-2564	375 845 000
	8.0	99-99-245	375 885 000
	9.6	99-100-245	375 945 000
Multigrip lockbolts	4.8	99-1456 ²	372 985 000
	6.4	99-1477UK ²	371 980 000
	7.8	99-1439	371 965 000
	9.6	99-1440	371 970 000
Hucktainer® Plus TIBULB blind rivets	9.5	99-3438	on request
	4.8		
	6.4		
M-LOCK blind rivets	7.8		
	4.8		
	6.4		
MAGNA-BULB blind rivets	9.5	99-3318	371 904 000
	4.8		
	6.4		
BOM blind rivets	7.8	99-3307	385 159 000
	4.8	99-1053	on request
	6.4	99-830-1	372 550 000
	9.5		

² Only to be fitted using a connector Article No. 375 870 000

For technical specifications on pulling heads, see table on pages 24/25.