



HL1

Manual rivet tool for installing M4 to M6 blind rivet nuts

Benefits at a glance

- Set comprising ratchet, hex key and installation head with threaded mandrel (M4, M5 or M6)
- Easy to operate and low-maintenance
- Sturdy design and low-weight
- Ideal for repairs or installing small quantities

Technical specifications

Weight: 0.8 kg

Scope of delivery

HL1 manual rivet tool (complete), comprising
 Ratchet
 Hex key
 Threaded mandrel
 Setting head
 Operating instructions



Ratchet (M4 - M6)



Hex key (M4 - M6)



Nose piece with threaded mandrel (M4, M5 oder M6)

	Article No.
HL1 manual rivet tool (complete) for M4	349 041 001
HL1 manual rivet tool (complete) for M5	349 051 001
HL1 manual rivet tool (complete) for M6	349 061 001

Working range

Blind rivet nuts	M4	M5	M6
Aluminium	•	•	•
Steel	•	•	•
Stainless steel	•	•	•

Spare parts / Consumables

Description	Article No.
Threaded mandrel M4	349 047 870
Threaded mandrel M5	349 057 870
Threaded mandrel M6	349 320 870
Setting head M4	349 304 870
Setting head M5	349 305 870
Setting head M6	349 306 870
Hex key for M4 - M6	349 311 870
Ratchet for M4 - M6	349 309 870

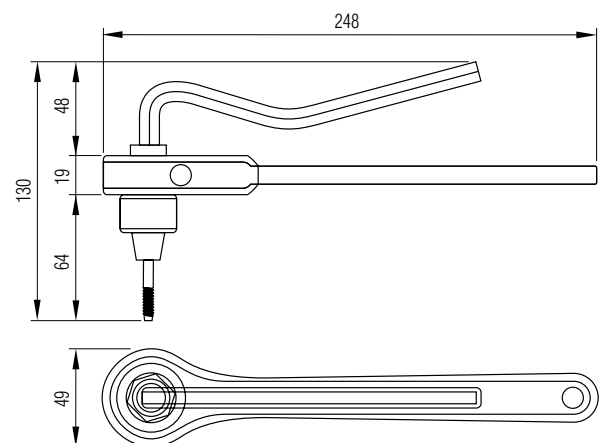



HL1M

Manual rivet tool for installing M8 to M20 blind rivet nuts

Benefits at a glance

- Set comprising ratchet, hex key and nose piece with threaded mandrel (M8, M10 or M12)
- Easy to use; requires little maintenance
- Sturdy design, low maintenance
- Ideal for repairs or installing small quantities of fasteners

Technical specifications

Weight: 0.8 kg

Scope of delivery

- HL1M manual rivet tool (complete), comprising
- Ratchet
- Hex key
- Threaded mandrel
- Setting head
- Operating instructions



Ratchet (M8 - M12)



Hex key (M8 - M12)



Setting head with threaded mandrel (M8, M10 or M12)

	Article No.
HL1M manual rivet tool (complete) for M8	349 081 001
HL1M manual rivet tool (complete) for M10	349 101 001
HL1M manual rivet tool (complete) for M12	349 121 001

Working range

Blind rivet nuts	M8	M10	M12
Aluminium	•	•	•
Steel	•	•	•
Stainless steel	•	•	•

Spare parts / Consumables

Description	Article No.
Threaded mandrel M8	349 302 870
Threaded mandrel M10	349 303 870
Threaded mandrel M12	349 322 870
Setting head M8	349 307 870
Setting head M10	349 308 870
Setting head M12	349 323 870
Hex key for M8 - M12	349 312 870
Ratchet wrench for M8 - M12	349 310 870

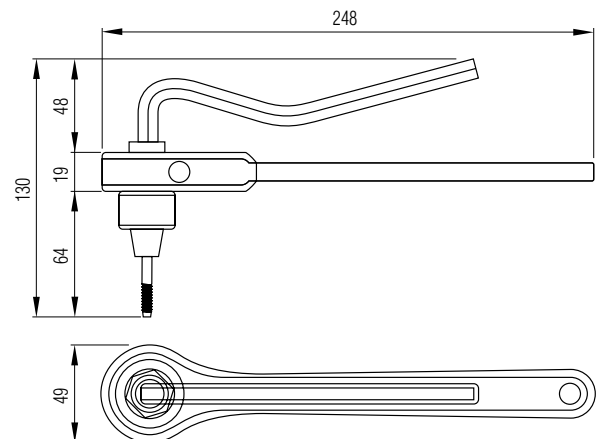



TIOS® HN6

Manual rivet tool for installing M3 - M6 blind rivet nuts and M4 - M6 blind rivet studs

Benefits at a glance

- Opening spring for one-handed operation
- Threaded mandrels for blind rivet nuts and blind rivet studs supplied with tool
- High-quality plier casing and handles
- Ergonomic handles
- Extremely easy operation and stroke settings

Technical specifications

Stroke: 7.0 mm
 Length: 265.0 mm
 Width: 134.0 mm
 Weight: 0.7 kg

Scope of delivery

TIOS HN6 manual rivet tool
 Threaded mandrels: M3 / M4* / M5* / M6*
 Nose pieces: M3 / M4 / M5 / M6
 Operating instructions
 Article No. 348 710 000



Working range

Blind rivet nuts	M3	M4	M5	M6
Aluminium, copper	•	•*	•*	•*
Steel	•	•*	•*	•*
Stainless steel	•	•*	•*	•*

* For use with blind rivet studs

Spare parts / Consumables

Description	Article No.
Threaded mandrel M3	348 710 103
Threaded mandrel M4	348 710 104
Threaded mandrel M5	348 710 105
Threaded mandrel M6	348 710 100
Setting head, complete, M3	348 710 203
Setting head, complete, M4	348 710 204
Setting head, complete, M5	348 710 205
Setting head, complete, M6	348 710 206

TIOS® HN10 S

Manual rivet tool for installing M4 - M10 blind rivet nuts with spindle mechanism

Benefits at a glance

- The threaded mandrel is turned by pulling on the spindle
- This makes for quick and easy pre-installation of the blind rivet nuts on the threaded mandrel
- Stroke scale on head side for easy stroke settings
- Tool-less rapid change system for threaded mandrels
- Threaded mandrels for blind rivet nuts included with delivery

Technical specifications

Stroke:	7.0 mm
Length:	480.0 mm
Width:	180.0 mm
Weight:	2.0 kg

Scope of delivery

TIOS HN10 S manual rivet tool
 Threaded mandrels: M4 / M5 / M6 / M8 / M10
 Nose pieces: M4 / M5 / M6 / M8 / M10
 Operating instructions
 Article No. 348 720 000



Working range

Blind rivet nuts	M4	M5	M6	M8	M10
Aluminium, copper	•	•	•	•	•
Steel	•	•	•	•	•
Stainless steel	•	•	•	•	•

Spare parts / Consumables

Description	Article No.
Threaded mandrel M4	348 720 104
Threaded mandrel M5	348 720 105
Threaded mandrel M6	348 720 106
Threaded mandrel M8	348 720 108
Threaded mandrel M10	348 720 110
Nose piece, complete, M4	348 720 114
Nose piece, complete, M5	348 720 113
Nose piece, complete, M6	348 720 112
Nose piece, complete, M8	348 720 111
Nose piece, complete, M10	348 720 115
Lockpin for threaded mandrel	348 740 303



TIOS® HN12 PT

Manual rivet tool for installing M4 - M12 blind rivet nuts, with ratchet action

Benefits at a glance

- Manual rivet tool with ratchet action
- Unique force transmission concept for blind rivet nuts up to M12 stainless steel
- Stroke scale on head side for easy stroke settings
- Tool-less rapid change system for threaded mandrels
- Threaded mandrels for blind rivet nuts included with delivery

Technical specifications

Stroke: 12.0 mm
 Length: 465.0 mm
 Width: 180.0 mm
 Weight: 1.8 kg

Scope of delivery

TIOS HN12 PT manual rivet tool
 Threaded mandrels: M4 / M5 / M6 / M8 / M10 / M12
 Nose pieces: M4 / M5 / M6 / M8 / M10 / M12
 Operating instructions
 Article No. 348 740 000



Working range

Blind rivet nuts	M4	M5	M6	M8	M10	M12
Aluminium, copper	•	•	•	•	•	•
Steel	•	•	•	•	•	•
Stainless steel	•	•	•	•	•	•

Spare parts / Consumables

Description	Article No.
Threaded mandrel M4	348 740 104
Threaded mandrel M5	348 740 105
Threaded mandrel M6	348 740 106
Threaded mandrel M8	348 740 108
Threaded mandrel M10	348 740 110
Threaded mandrel M12	348 740 112
Nose piece, complete, M4	348 740 116
Nose piece, complete, M5	348 740 115
Nose piece, complete, M6	348 740 114
Nose piece, complete, M8	348 740 109
Nose piece, complete, M10	348 740 113
Nose piece, complete, M12	348 740 111
Lockpin for threaded mandrel	348 740 303



TIOS® HN12 R

Manual rivet tool for installing M5 - M12 blind rivet nuts

Benefits at a glance

- Ratchet action for maximum force transmission in confined spaces
- The upper lever turns around its middle axis
- Patented telescopic lever for customised adjustment of lever lengths
- Stroke scale for easy stroke settings
- Tool-less rapid change system for threaded mandrels
- Threaded mandrels for blind rivet nuts included with delivery

Technical specifications

Stroke: 10.0 mm
 Length: 219.0 - 317.0 mm
 Width: 177.0 mm
 Weight: 1.5 kg

Scope of delivery

TIOS HN12 R manual rivet tool
 Threaded mandrels: M5 / M6 / M8 / M10 / M12
 Nose pieces: M5 / M6 / M8 / M10 / M12
 Operating instructions
 Article No. 348 730 000

Working range

Blind rivet nuts	M5	M6	M8	M10	M12
Aluminium, copper	•	•	•	•	•
Steel	•	•	•	•	•
Stainless steel	•	•	•	•	•

Spare parts / Consumables

Description	Article No.
Threaded mandrel M5	348 730 101
Threaded mandrel M6	348 730 102
Threaded mandrel M8	348 730 103
Threaded mandrel M10	348 730 104
Threaded mandrel M12	348 730 105
Nose piece M5	348 730 106
Nose piece M6	348 730 107
Nose piece M8	348 730 108
Nose piece M10	348 730 109
Nose piece M12	348 730 110

