



TIFAS® expanding shank plastic rivets



TIFAS® expanding shank plastic rivets are installed on one side using your thumb and can be used for a diverse range of applications: on the back of components that are impossible or very difficult to access, e.g. to fasten panels, type plates and signs or all types of covers. TIFAS® expanding shank plastic rivets are dielectric (non-conductive), made of viscoelastic, corrosion-free material and lightweight. The smooth, large rivet head provides an outside cap for the expanding rivet to create a visually appealing finish.

Benefits at a glance

- Suitable for securing components
- Can be installed by hand by applying a slight amount of pressure
- Universal use
- Quick and secure installation
- Heatless installation means component will not warp.
- Eliminates extensive refinishing
- Corrosion-free

Installation steps

1. Insert TIFAS® expanding shank rivet into the hole
2. Using your thumb, apply pressure to the rivet head to set the rivet
3. The TIFAS® expanding shank rivet is installed

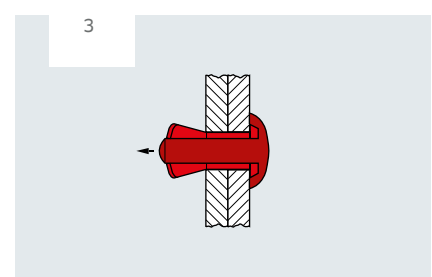
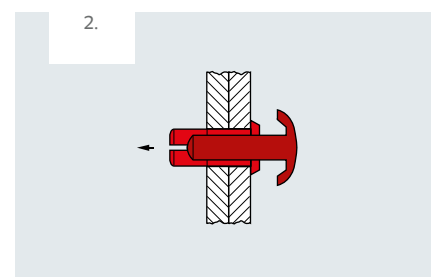
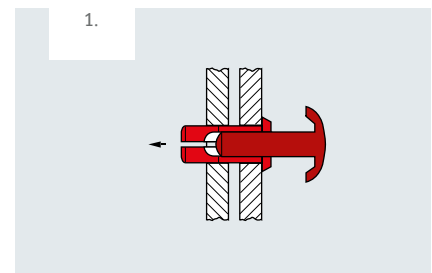



TIFAS® expanding shank plastic rivets

Round head

Material

Plastic PA 6.6,
black

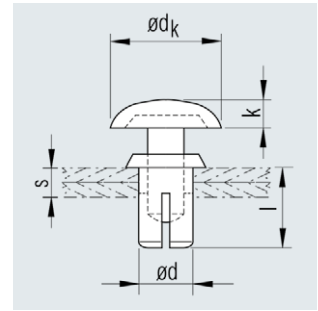

Nominal \varnothing d [mm]	Bore \varnothing [mm]	Grip range s [mm]	Sleeve l max [mm]	Rivet head \varnothing dk +0.1 -0.3 [mm]	Height k +0.1 -0.2 [mm]	Shank slits	Article No.
3.0	3.1 - 3.2	2.0 - 3.0	4.5	6.5	2.0	2	409 531 000
		3.0 - 4.0	5.5	6.5	2.0	2	409 532 000
		4.0 - 5.0	6.5	6.5	2.0	2	409 533 000
		5.0 - 6.0	8.0	6.5	2.0	2	409 534 000
4.0	4.2 - 4.3	1.5 - 2.5	4.5	8.5	2.0	4	409 540 000
		2.5 - 3.5	5.5	8.5	2.0	4	409 541 000
		3.5 - 4.5	6.5	8.5	2.0	4	409 542 000
		4.5 - 5.5	7.5	8.5	2.0	4	409 543 000
		5.5 - 6.5	8.5	8.5	2.0	4	409 544 000
5.0	5.2 - 5.3	1.5 - 2.5	4.5	9.0	2.1	5	409 550 000
		2.5 - 3.5	5.5	9.0	2.1	5	409 551 000
		3.5 - 4.5	6.5	9.0	2.1	5	409 552 000
		4.5 - 5.5	7.5	9.0	2.1	5	409 553 000
		5.5 - 6.5	8.5	9.0	2.1	5	409 554 000
		6.5 - 7.5	9.5	9.0	2.1	5	409 555 000
6.0	6.4 - 6.5	7.5 - 8.5	10.5	9.0	2.1	5	409 556 000
		1.5 - 2.5	4.5	11.0	2.9	5	409 560 000
		2.5 - 3.5	5.5	11.0	2.9	5	409 561 000
		3.5 - 4.5	6.5	11.0	2.9	5	409 562 000
		4.5 - 5.5	7.5	11.0	2.9	5	409 563 000
		5.5 - 6.5	8.5	11.0	2.9	5	409 564 000
		6.5 - 7.5	9.5	11.0	2.9	5	409 565 000
7.5 - 8.5	10.5	11.0	2.9	5	409 566 000		

Other designs available on request.



TIFAS® expanding shank plastic rivets

Round head

Material

Plastic PA 6.6,
white

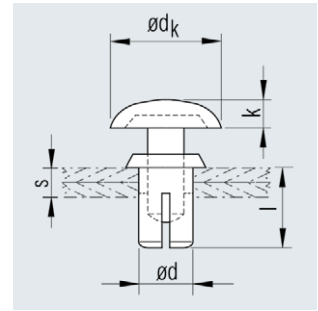

Nominal \varnothing d [mm]	Bore \varnothing [mm]	Grip range s [mm]	Sleeve l max [mm]	Rivet head		Shank slits	Article No.
				\varnothing dk +0.1 -0.3 [mm]	Height k +0.1 -0.2 [mm]		
3.0	3.1 - 3.2	2.0 - 3.0	4.5	6.5	2.0	2	409 631 000
		3.0 - 4.0	5.5	6.5	2.0	2	409 632 000
		4.0 - 5.0	6.5	6.5	2.0	2	409 633 000
		5.0 - 6.0	8.0	6.5	2.0	2	409 634 000
4.0	4.2 - 4.3	1.5 - 2.5	4.5	8.5	2.0	4	409 640 000
		2.5 - 3.5	5.5	8.5	2.0	4	409 641 000
		3.5 - 4.5	6.5	8.5	2.0	4	409 642 000
		4.5 - 5.5	7.5	8.5	2.0	4	409 643 000
		5.5 - 6.5	8.5	8.5	2.0	4	409 644 000
5.0	5.2 - 5.3	1.5 - 2.5	4.5	9.0	2.1	5	409 650 000
		2.5 - 3.5	5.5	9.0	2.1	5	409 651 000
		3.5 - 4.5	6.5	9.0	2.1	5	409 652 000
		4.5 - 5.5	7.5	9.0	2.1	5	409 653 000
		5.5 - 6.5	8.5	9.0	2.1	5	409 654 000
		6.5 - 7.5	9.5	9.0	2.1	5	409 655 000
6.0	6.4 - 6.5	7.5 - 8.5	10.5	9.0	2.1	5	409 656 000
		1.5 - 2.5	4.5	11.0	2.9	5	409 660 000
		2.5 - 3.5	5.5	11.0	2.9	5	409 661 000
		3.5 - 4.5	6.5	11.0	2.9	5	409 662 000
		4.5 - 5.5	7.5	11.0	2.9	5	409 663 000
		5.5 - 6.5	8.5	11.0	2.9	5	409 664 000
		6.5 - 7.5	9.5	11.0	2.9	5	409 665 000
7.5 - 8.5	10.5	11.0	2.9	5	409 666 000		

Other designs available on request.