

Fastening Technology / Lockbolt Systems

Bobtail®

Lockbolt System - Pintail-less Design







Contents

			Page
Lockbolt systems	Bobtail® Lockbolt systems - pintail-less	Overview	4
		Truss	6
		Flanged collar	8



BobTail® lockbolts



Faster installation, easier tools, more time-savings

The BobTail® lockbolt system offers the highest levels of safety for all permanent fastener applications. BobTail® is the next evolution in Huck pin and collar technology - with an array of outstanding features going for it: there are no breakoff pintails, no mandrels, no corrosion points - in other words, no waste. Compliance with environmental and noise emissions is no issue whatsoever, as the typical bang otherwise heard on installation has been eliminated. The availability of significantly lighter tools makes for a more ergonomic process and more efficient performance. Unlike conventional fastener systems, these pins are especially ideal for permanently marrying different materials, such as steel, stainless steel, aluminium alloys, or plastics. This ability to perform with mixed

structures benefits lightweight construction and reduces the mass weight of the overall design.

BobTail® is a grade 10.9 bolt that stands out for its high fatigue and clamp strength with a high dynamic load. The readily identifiable economic and ecological benefits make the BobTail® lockbolt system a highly attractive product for fulfilling the demands that trade and industry place on modern fasteners - especially the commercial vehicle and automotive sectors.

Tools to match the BobTail®

Special hydraulic tools are available for installing the BobTail® lockbolt system. These comprise a nose assembly and puller, along with a hydraulic power unit. The tools have also been designed for lockbolt pre-assembly. The bolt is held in place by a fixing attached to the collar. This ensures that every lockbolt is installed to the

same high level. Installing the bolts is exceptionally easy and barely takes 2 seconds per fastener. The strength values for the fastener are generated automatically during the installation sequence. No tightening or retorque is needed. Unlike conventional nuts and bolts, lockbolts will not come loose even when subjected to heavy vibrations. A simple visual inspection is all that is needed to determine if the fastener has been correctly installed. The tools have been engineered to enable even untrained operators to constantly achieve the same high levels of quality after some brief training.



Benefits at a glance

- No pintail, no pin break
- Lower material consumption
- Low installation noise, no banging noise
- Increased corrosion resistance
- Pre-assembly possible
- Quick and easy installation
- No installation tool recoil
- No discharged pintails
- No corrosion-prone breakneck grooves
- High-strength, grade 10.9 fasteners
- High-quality, corrosion-resistant coating systems possible
- Installation indicator on collar for visual installation inspection

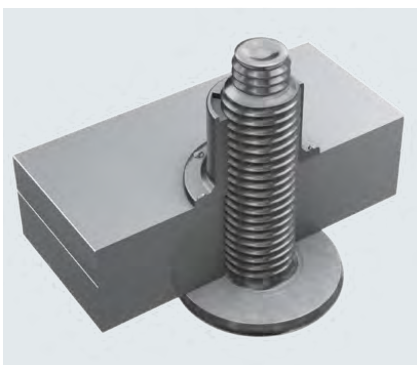

Installation steps

1. Pre-assembly: The pin is inserted into the prepared hole, and the collar is rotated onto the pin.
2. The nose assembly is applied to the pin grooves: The tool is applied to the annular pull grooves and triggered. A puller in the nose assembly draws the pin into the tool. The anvil presses the collar against the pin and tension loads the joint.
3. As the nose assembly continues to pull, the anvil swages the collar. The material flows into the lock grooves, with part of it also being pressed towards the component. This significantly increases the clamp force between the two components.
4. The anvil retracts and the jaws are released. The swaging of the collar is complete. The tool ejects the fastener. The installation sequence is complete.

Please note:

The markings (swage indicators) on the flange are used to visually check that the fastener has been properly installed. The installation is correct if the swage indicators are indented. A ring gauge can also be used to check if the collar has been swaged.

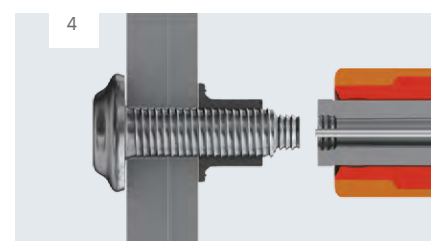
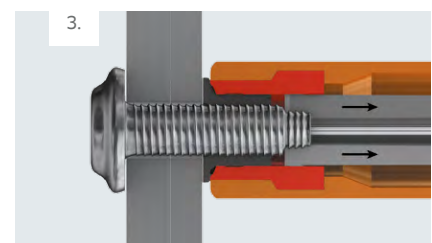
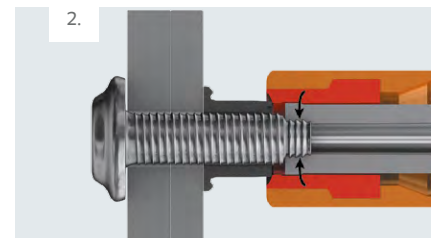
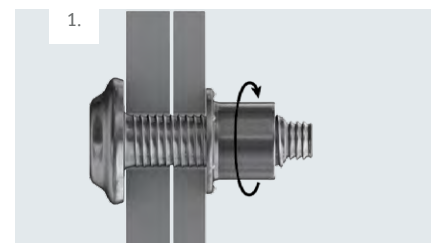

Bobtail® lockbolt systems - pintail-less



Truss

Material

Carbon steel 10.9, black

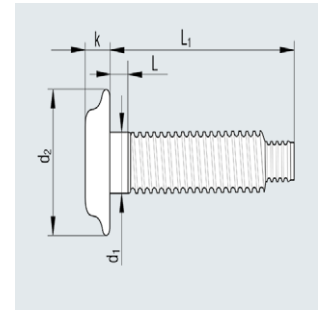
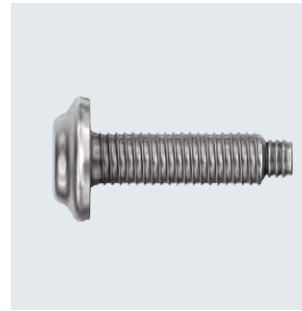

Nominal bolt \varnothing	Bore \varnothing	Grip range						Shear strength	Tensile strength	Clamp	Article No.
[mm]	[mm]	s [mm]	L [mm]	L1 max [mm]	d1 [mm]	d2 [mm]	k max [mm]	[N]	[N]	[N]	
12.0	12.0 - 13.5	5.0 - 15.0	3.8	46.1	12.0	25.4	9.6	65400	87700	64900	380 180 000
		10.0 - 20.0	3.8	51.1	12.0	25.4	9.6	65400	87700	64900	380 181 000
		15.0 - 25.0	3.8	56.1	12.0	25.4	9.6	65400	87700	64900	380 182 000
		20.0 - 30.0	3.8	61.1	12.0	25.4	9.6	65400	87700	64900	380 183 000
		25.0 - 35.0	3.8	66.1	12.0	25.4	9.6	65400	87700	64900	380 184 000
		30.0 - 40.0	3.8	71.1	12.0	25.4	9.6	65400	87700	64900	380 185 000
		35.0 - 45.0	3.8	76.1	12.0	25.4	9.6	65400	87700	64900	380 186 000
		40.0 - 50.0	3.8	81.1	12.0	25.4	9.6	65400	87700	64900	380 187 000
		45.0 - 55.0	3.8	86.1	12.0	25.4	9.6	65400	87700	64900	380 188 000
		50.0 - 60.0	3.8	91.1	12.0	25.4	9.6	65400	87700	64900	380 189 000
		55.0 - 65.0	3.8	96.1	12.0	25.4	9.6	65400	87700	64900	380 190 000
		60.0 - 70.0	3.8	101.1	12.0	25.4	9.6	65400	87700	64900	380 191 000
		65.0 - 75.0	3.8	106.1	12.0	25.4	9.6	65400	87700	64900	380 192 000
		70.0 - 80.0	3.8	111.1	12.0	25.4	9.6	65400	87700	64900	380 193 000
		75.0 - 85.0	9.5	116.1	12.0	25.4	9.6	65400	87700	64900	380 194 000
14.0	14.0 - 15.5	5.0 - 15.0	3.8	49.0	14.0	30.0	11.5	94000	120000	87000	380 280 000
		10.0 - 20.0	3.8	54.0	14.0	30.0	11.5	94000	120000	87000	380 281 000
		15.0 - 25.0	3.8	59.0	14.0	30.0	11.5	94000	120000	87000	380 282 000
		20.0 - 30.0	3.8	64.0	14.0	30.0	11.5	94000	120000	87000	380 283 000
		25.0 - 35.0	3.8	69.0	14.0	30.0	11.5	94000	120000	87000	380 284 000
		30.0 - 40.0	3.8	74.0	14.0	30.0	11.5	94000	120000	87000	380 285 000
		35.0 - 45.0	3.8	79.0	14.0	30.0	11.5	94000	120000	87000	380 286 000
		40.0 - 50.0	3.8	84.0	14.0	30.0	11.5	94000	120000	87000	380 287 000
		45.0 - 55.0	3.8	89.0	14.0	30.0	11.5	94000	120000	87000	380 288 000
		50.0 - 60.0	3.8	94.0	14.0	30.0	11.5	94000	120000	87000	380 289 000
		55.0 - 60.0	3.8	99.0	14.0	30.0	11.5	94000	120000	87000	380 290 000
		60.0 - 70.0	3.8	104.0	14.0	30.0	11.5	94000	120000	87000	380 291 000
		65.0 - 75.0	3.8	109.0	14.0	30.0	11.5	94000	120000	87000	380 292 000
		70.0 - 80.0	9.5	114.0	14.0	30.0	11.5	94000	120000	87000	380 293 000
		75.0 - 85.0	9.5	119.0	14.0	30.0	11.5	94000	120000	87000	380 294 000

Continued on next page



Cont'd

Nominal bolt ø	Bore ø	Grip range						Shear strength	Tensile strength	Clamp	Article No.
[mm]	[mm]	s [mm]	L [mm]	L1 max [mm]	d1 [mm]	d2 [mm]	k max [mm]	[N]	[N]	[N]	
16.0	16.0 - 17.5	5.0 - 15.0	3.8	52.0	16.0	33.8	12.2	122000	163000	116000	380 380 000
		10.0 - 20.0	3.8	57.0	16.0	33.8	12.2	122000	163000	116000	380 381 000
		15.0 - 25.0	3.8	62.0	16.0	33.8	12.2	122000	163000	116000	380 382 000
		20.0 - 30.0	3.8	67.0	16.0	33.8	12.2	122000	163000	116000	380 383 000
		25.0 - 35.0	3.8	72.0	16.0	33.8	12.2	122000	163000	116000	380 384 000
		30.0 - 40.0	3.8	77.0	16.0	33.8	12.2	122000	163000	116000	380 385 000
		35.0 - 45.0	3.8	82.0	16.0	33.8	12.2	122000	163000	116000	380 386 000
		40.0 - 50.0	3.8	87.0	16.0	33.8	12.2	122000	163000	116000	380 387 000
		45.0 - 55.0	9.5	92.0	16.0	33.8	12.2	122000	163000	116000	380 388 000
		50.0 - 60.0	9.5	97.0	16.0	33.8	12.2	122000	163000	116000	380 389 000
		55.0 - 65.0	9.5	102.0	16.0	33.8	12.2	122000	163000	116000	380 390 000
		60.0 - 70.0	9.5	107.0	16.0	33.8	12.2	122000	163000	116000	380 391 000
		65.0 - 75.0	9.5	112.0	16.0	33.8	12.2	122000	163000	116000	380 392 000
		70.0 - 80.0	9.5	117.0	16.0	33.8	12.2	122000	163000	116000	380 393 000
		75.0 - 85.0	9.5	122.0	16.0	33.8	12.2	122000	163000	116000	380 394 000
20.0	20.0 - 22.0	5.0 - 15.0	3.8	60.7	20.0	42.4	16.0	191000	255000	181000	380 480 000
		10.0 - 20.0	3.8	65.7	20.0	42.4	16.0	191000	255000	181000	380 481 000
		15.0 - 25.0	3.8	70.7	20.0	42.4	16.0	191000	255000	181000	380 482 000
		20.0 - 30.0	3.8	75.7	20.0	42.4	16.0	191000	255000	181000	380 483 000
		25.0 - 35.0	3.8	80.7	20.0	42.4	16.0	191000	255000	181000	380 484 000
		30.0 - 40.0	3.8	85.7	20.0	42.4	16.0	191000	255000	181000	380 485 000
		35.0 - 45.0	3.8	90.7	20.0	42.4	16.0	191000	255000	181000	380 486 000
		40.0 - 50.0	3.8	95.7	20.0	42.4	16.0	191000	255000	181000	380 487 000
		45.0 - 55.0	3.8	100.7	20.0	42.4	16.0	191000	255000	181000	380 488 000
		50.0 - 60.0	3.8	105.7	20.0	42.4	16.0	191000	255000	181000	380 489 000
		55.0 - 65.0	3.8	110.7	20.0	42.4	16.0	191000	255000	181000	380 490 000
		60.0 - 70.0	9.5	115.7	20.0	42.4	16.0	191000	255000	181000	380 491 000
		65.0 - 75.0	9.5	120.7	20.0	42.4	16.0	191000	255000	181000	380 492 000
		70.0 - 80.0	9.5	125.7	20.0	42.4	16.0	191000	255000	181000	380 493 000
		75.0 - 85.0	9.5	130.7	20.0	42.4	16.0	191000	255000	181000	380 494 000

Other designs available on request.

Bobtail® lockbolt systems – pintail-less



Flanged collar

Material

Carbon steel 10.9, black

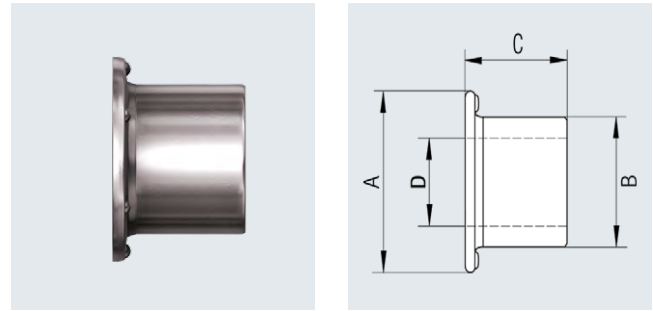

For nominal bolt ø [mm]	A nom [mm]	B nom [mm]	C max [mm]	D max [mm]	Article No.
12.0	25.4	18.4	17.7	12.3	380 199 000
14.0	30.0	21.5	21.5	14.4	380 299 000
16.0	33.8	24.5	23.7	16.4	380 399 000
20.0	42.4	30.6	29.6	20.5	380 499 000

Other designs available on request.