

Fastening Technology / Lockbolt Systems

TIFAS[®] LockBolt Multigrip

Lockbolt System with extended grip range







Contents

			Page
TIFAS® LockBolt Multigrip	Overview		4
	Brazier	Steel, galvanised	6
		Aluminium	7
	Large brazier head	Steel, galvanised	8
		Aluminium	9
	Countersunk 90°	Steel, galvanised	10
		Aluminium	11
	Flanged collar	Steel, galvanised	12
		Aluminium	13



TIFAS® Lockbolt Multigrip

The lockbolt system with very large grip range.



Lockbolts are ideal for permanently and securely fastening two parts together so that they will never detach, even when subjected to preload or dynamic load.

Unlike the standard lockbolt system, the TIFAS® LockBolt Multigrip pin and collar system does not have a pre-defined breakload. The breakoff force for the pin tail can be set variably within a predefined range, whilst the pin offers a very large grip range for the parts to be fastened. The break-neck groove is always located just before the end of the collar. As a result, the pin on the steel version will not protrude at the fastening point in spite of the compensatory tolerance this design offers.

Even when subjected to vibrations, the applied clamp force remains constant. As a positive locking device that fastens permanently with the bolt, the collar is impossible to remove.



Benefits at a glance

- Very large grip range
- Rational fastening system – one lockbolt covers a very large area of installation
- Compensates for extensive differences in wall thickness
- Pin tip breaks off inside the collar (steel version)
- No protruding pin tip, no sharp edges (steel version)
- High clamp force
- Installation steps make for safe build-up of clamp force
- Constant clamp force/preload
- Vibration resistant
- No heat exposure around the joint
- No warping
- No refinishing required around the joint
- No surface damage on components
- Visual inspection
- Installation can be checked using process monitoring
- Maintenance-free
- Quick and easy installation

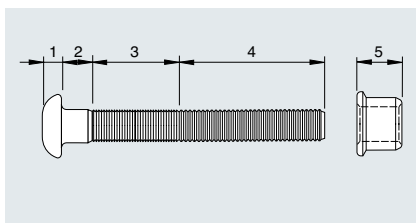

Composition

- 1 = Brazier or countersunk head
- 2 = Smooth pin shank
- 3 = Locking grooves into which the collar is swaged
- 4 = Pin tail (for installation tool)
- 5 = Flanged collar with cone-shaped tip

Installation steps

1. Select lockbolts based on the specified requirements as well as the clamping thicknesses available on-site (sum total of all wall thicknesses to be installed)
2. Select the installation tool, incl. pulling head that matches the lockbolts to be installed (for details, see "Overview - Lockbolts" in the "Tools for Lockbolts" catalogue)
3. Insert the bolt into both through-holes on the components and, with the chamfer aligned to the end of the bolt, slide the collar over the lockbolt. (Fig. 1)
4. Fully press the installation tool with attached pulling head against the collar while securing the pin in place from the opposite side to prevent it from being poked out. (Fig. 2)
5. Press the trigger on the installation tool. The jaws then grip into the grooves on the pin tail and tug at the pin. The pulling head sleeve presses up against the components and the resulting clamp force pushes them together. (Fig. 3)
6. As the tool continues to pull, the pulling head sleeve slides over the collar. (Fig. 4) This reduces the external diameter of the collar. The compressed material slides into the locking grooves of the bolt to form the desired positive fit. As the front side of the sleeve elongates, it is pushed up against the component to create the desired preload where the parts connect.
7. The tool will continue to pull until the lockbolt's breakload is achieved, causing the tip of the bolt (pulling head) to snap off at the end of the collar (steel version). Installation is now complete. (Fig. 5)

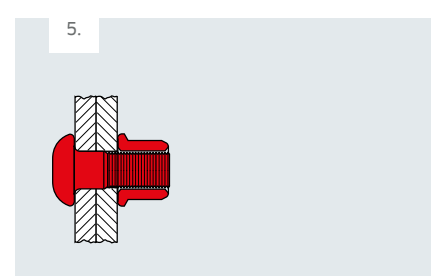
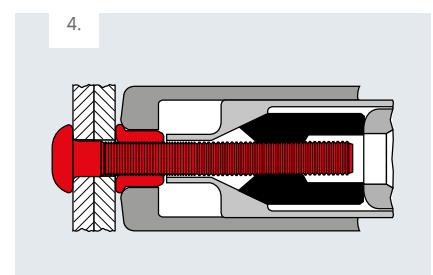
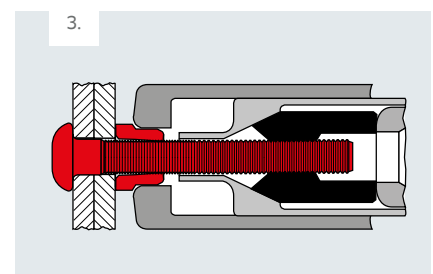
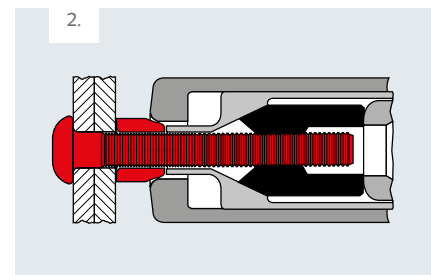
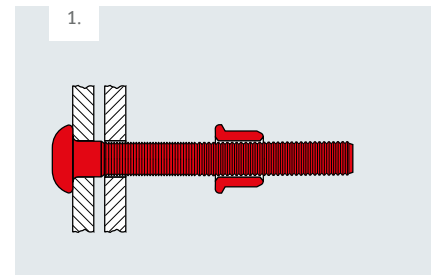
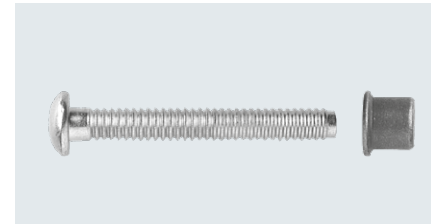



TIFAS® LockBolt Multigrip

Brazier

Material

Steel, tempered (Type 5) galvanised, passivated

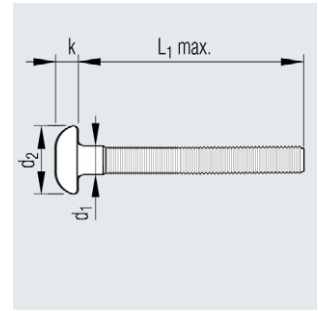

Nominal bolt \varnothing d1 [mm]	Bore \varnothing -0.2 [mm]	Grip range [mm]	L1 max [mm]	d1 -0.2 [mm]	d2 max [mm]	k max [mm]	Shear strength [N]	Tensile strength [N]	Clamp [N]	Article No.
4.8	5.2	1.6 - 16.0	48.0	5.0	10.1	3.3	7500	7300	4000	378 900 001
		8.0 - 32.0	61.0	5.0	10.1	3.3	7500	7300	4000	378 904 001
6.4	6.8	1.6 - 16.0	52.5	6.6	13.4	4.0	9800	13300	5300	378 908 001
		8.0 - 32.0	67.0	6.6	13.4	4.0	9800	13300	5300	378 912 001

The tensile strength and clamp shown may be lower in practice and are for guidance purposes only.
 Lockbolts with a surface coating (zinc, clear passivate) have approx. 15% less tensile strength than shown.
 For more detailed information, please contact your representative at our company.
 Flanged collars will need to be ordered separately.

Other designs available on request.

TIFAS® LockBolt Multigrip



Brazier

Material

Aluminium EN AW 7075

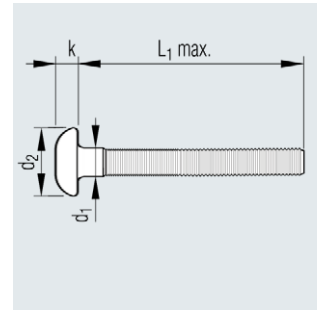
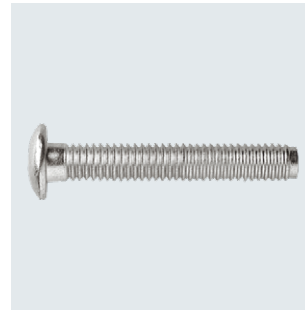

Nominal bolt \varnothing d1 [mm]	Bore \varnothing -0.2 [mm]	Grip range [mm]	L1 max [mm]	d1 -0.2 [mm]	d2 max [mm]	k max [mm]	Shear strength [N]	Tensile strength [N]	Clamp [N]	Article No.
4.8	5.2	1.6 - 16.0	48.0	5.0	10.1	3.3	3300	4000	2500	378 950 001
		8.0 - 32.0	61.0	5.0	10.1	3.3	3300	4000	2500	378 954 001
6.4	6.8	3.2 - 16.0	52.5	6.6	13.4	4.0	5300	7200	4000	378 958 001
		8.0 - 32.0	67.0	6.6	13.4	4.0	5300	7200	4000	378 962 001

The tensile strength and clamp shown may be lower in practice and are for guidance purposes only.
For more detailed information, please contact your representative at our company.
Flanged collars will need to be ordered separately.

Other designs available on request.

Please note:

The break-off point on the bolt may vary depending on the properties of the materials used.



TIFAS® LockBolt Multigrip

Large brazier head

Material

Steel, tempered (Type 5) galvanised, passivated

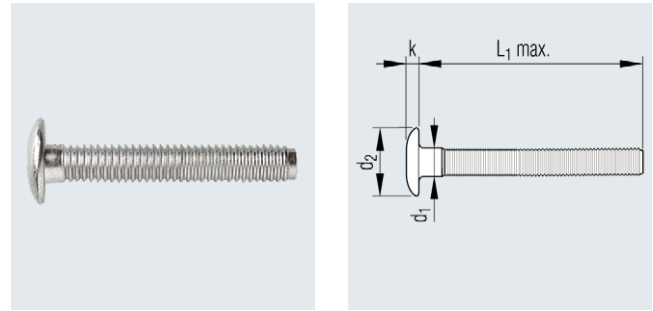

Nominal bolt \varnothing d1 [mm]	Bore \varnothing -0.2 [mm]	Grip range [mm]	L1 max [mm]	d1 -0.2 [mm]	d2 max [mm]	k max [mm]	Shear strength [N]	Tensile strength [N]	Clamp [N]	Article No.
4.8	5.2	1.6 - 16.0	48.0	5.0	12.6	3.0	7500	7300	4000	378 902 001
		8.0 - 32.0	61.0	5.0	12.6	3.0	7500	7300	4000	378 905 001
6.4	6.8	1.6 - 16.0	52.5	6.6	15.3	3.6	9800	13300	5300	378 910 001
		8.0 - 32.0	67.0	6.6	15.3	3.6	9800	13300	5300	378 914 001

The tensile strength and clamp shown may be lower in practice and are for guidance purposes only.
 Lockbolts with a surface coating (zinc, clear passivate) have approx. 15% less tensile strength than shown.
 For more detailed information, please contact your representative at our company.
 Flanged collars will need to be ordered separately.

Other designs available on request.



TIFAS® LockBolt Multigrip

Large brazier head

Material

Aluminium EN AW 7075

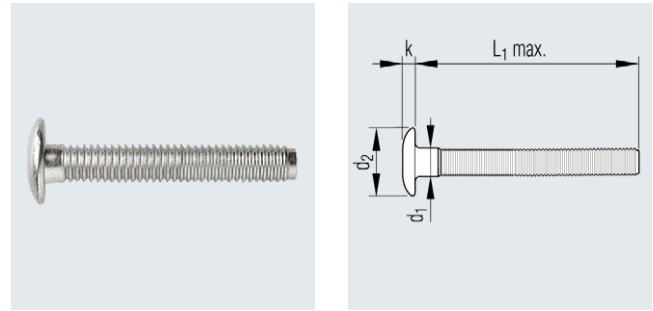

Nominal bolt \varnothing d1 [mm]	Bore \varnothing -0.2 [mm]	Grip range [mm]	L1 max [mm]	d1 -0.2 [mm]	d2 max [mm]	k max [mm]	Shear strength [N]	Tensile strength [N]	Clamp [N]	Article No.
4.8	5.2	1.6 - 16.0	48.0	5.0	12.6	3.0	3300	4000	2500	378 952 001
		8.0 - 32.0	61.0	5.0	12.6	3.0	3300	4000	2500	378 955 001
6.4	6.8	3.2 - 16.0	52.5	6.6	15.3	3.6	5300	7200	4000	378 960 001
		8.0 - 32.0	67.0	6.6	15.3	3.6	5300	7200	4000	378 963 001

The tensile strength and clamp shown may be lower in practice and are for guidance purposes only.
For more detailed information, please contact your representative at our company.
Flanged collars will need to be ordered separately.

Other designs available on request.

Please note:

The break-off point on the bolt may vary depending on the properties of the materials used.

TIFAS® LockBolt Multigrip



Countersunk 90°

Material

Steel, tempered (Type 5) galvanised, passivated

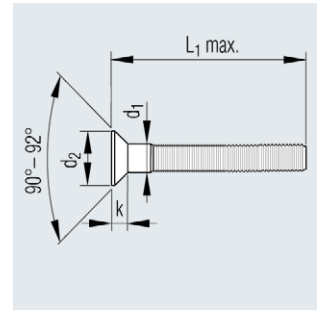
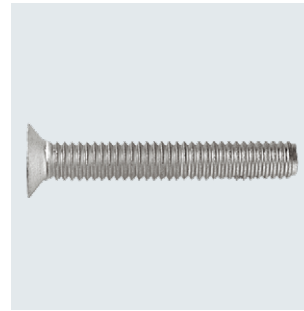

Nominal bolt \varnothing d1 [mm]	Bore \varnothing -0.2 [mm]	Grip range [mm]	L1 max [mm]	d1 -0.2 [mm]	d2 max [mm]	k max [mm]	Shear strength [N]	Tensile strength [N]	Clamp [N]	Article No.
4.8	5.2	3.6 - 16.0	48.0	5.0	9.3	2.6	7500	7300	4000	378 903 001
		8.0 - 32.0	61.0	5.0	9.3	2.6	7500	7300	4000	378 907 001
6.4	6.8	4.3 - 16.0	52.5	6.6	12.2	3.3	9800	13300	5300	378 911 001
		8.0 - 32.0	67.0	6.6	12.2	3.3	9800	13300	5300	378 915 001

The tensile strength and clamp shown may be lower in practice and are for guidance purposes only.
 Lockbolts with a surface coating (zinc, clear passivate) have approx. 15% less tensile strength than shown.
 For more detailed information, please contact your representative at our company.
 Flanged collars will need to be ordered separately.

Other designs available on request.

TIFAS® LockBolt Multigrip



Countersunk 90°

Material

Aluminium EN AW 7075

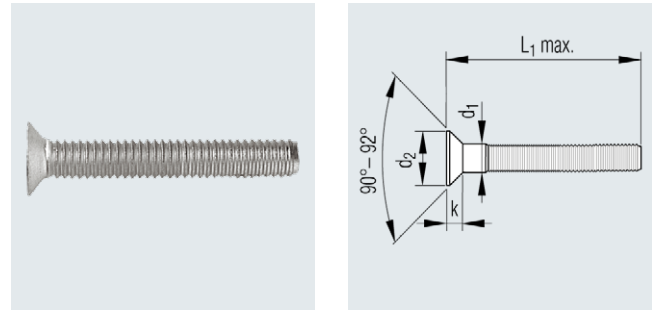

Nominal bolt \varnothing d1 [mm]	Bore \varnothing -0.2 [mm]	Grip range [mm]	L1 max [mm]	d1 -0.2 [mm]	d2 max [mm]	k max [mm]	Shear strength [N]	Tensile strength [N]	Clamp [N]	Article No.
4.8	5.2	3.6 - 16.0	48.0	5.0	9.3	2.6	3300	4000	2500	378 953 001
		8.0 - 32.0	61.0	5.0	9.3	2.6	3300	4000	2500	378 957 001
6.4	6.8	4.3 - 16.0	52.5	6.6	12.2	3.3	5300	7200	4000	378 961 001
		8.0 - 32.0	67.0	6.6	12.2	3.3	5300	7200	4000	378 965 001

The tensile strength and clamp shown may be lower in practice and are for guidance purposes only.
For more detailed information, please contact your representative at our company.
Flanged collars will need to be ordered separately.

Other designs available on request.

Please note:

The break-off point on the bolt may vary depending on the properties of the materials used.

TIFAS® LockBolt Multigrip



Flanged collar

Material

Steel, tempered, galvanised, passivated

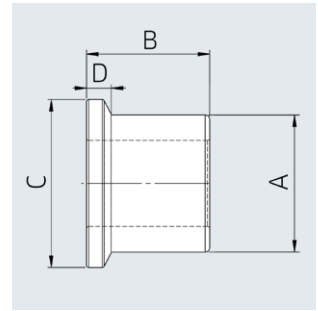

For nominal bolt ø	A min	B max	C max	D max	Article No.
[mm]	[mm]	[mm]	[mm]	[mm]	
4.8	7.7	7.2	9.8	1.6	378 940 001
6.4	10.2	9.7	13.1	1.8	378 941 001

All collars supplied with added lubricant.

Other designs available on request.



TIFAS® LockBolt Multigrip

Flanged collar

Material

Aluminium EN AW 6061

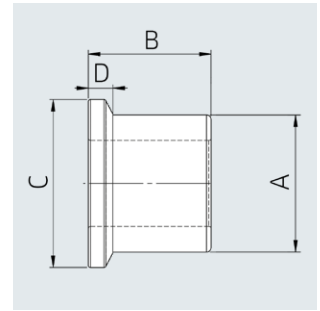

For nominal bolt \varnothing	A min [mm]	B max [mm]	C max [mm]	D max [mm]	Article No.
4.8	7.7	7.2	9.8	4.6	378 990 001
6.4	10.2	9.7	13.1	1.8	378 991 001

All collars supplied with added lubrication.

Other designs available on request.